



GM12-75

12V 75AH AGM Battery

Characteristics

Nominal Voltage		12V
Nominal Capacity (10 hour rate)		75Ah
Capacity 25°C (77°F)	10 hour rate (7.5A)	75Ah
	3 hour rate (19.9A)	59.7Ah
	1 hour rate (48.7A)	48.7Ah
Internal Resistance	Full Charged Battery 25°C (77°F)	≤7mΩ
Cyclic Life	50%(C ₁₀) Depth of discharge	1000Times
	30%(C ₁₀) Depth of discharge	1200Times
	20%(C ₁₀) Depth of discharge	1400Times
Float Life	25°C (77°F) Float charge at 13.8V	About 10-12 Years
Capacity affected by Temperature (10 hour)	40°C (104°F)	102%
	25°C (77°F)	100%
	0°C (32°F)	85%
	-15°C (5°F)	65%
Self-Discharge 25°C (77°F)	Capacity after 3 month storage	90%
	Capacity after 6 month storage	80%
	Capacity after 12 month storage	62%
Charge (Constant Voltage) 25°C (77°F)	Cycle	Initial Charging Current Less than 22.5A Voltage 14.6-15.0V
	Float	Voltage 13.5-13.8V
Operating Temperature Range during Charging/ Discharging		-15°C to 45°C

Product Image



Packing

Battery (L×W×H)	mm±1	259×169×227
	inch	10.2×6.66×8.94
Box (L×W×H)	mm±2	285×190×270
	inch	11.3×7.48×10.7
Quantity Per Box		1 PCS
Net weight Per Cell		22 Kg±200g
Net weight Per Box		22.0 Kg
Gross Weight		22.4 Kg

Product Dimensions

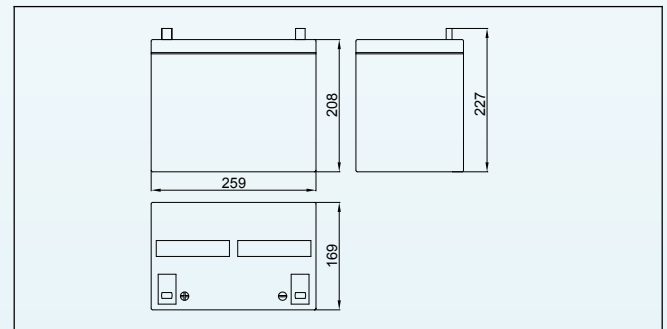

Discharge Curve

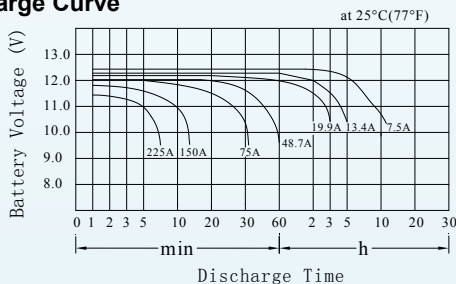

Battery Construction

Component	Positive plate	Negative plate	Container	Safety valve	Terminal	Separator	Electrolyte
Raw Material	Lead dioxide	Lead	ABS	Rubber	Copper/Pb	Fiberglass	Sulfuric acid

Discharge Characteristics

Voltage	Run Time (Constant Current and Power 25°C 77°F)										
	3 min	5 min	15 min	30 min	45 min	1h	2h	3h	5h	8h	10h
9.6 V	3278	2850	1613	1035	773	559	315	237	158	105	93
10.2V	3150	2438	1448	923	743	552	304	233	156	104	92
10.5V	2888	2310	1365	840	728	543	293	229	154	102	91
10.8V	2640	2198	1185	750	705	533	285	218	147	101	90

Discharge Characteristics Curve

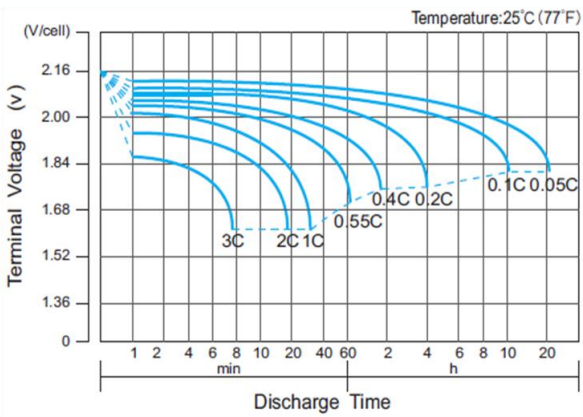

Charging Characteristics

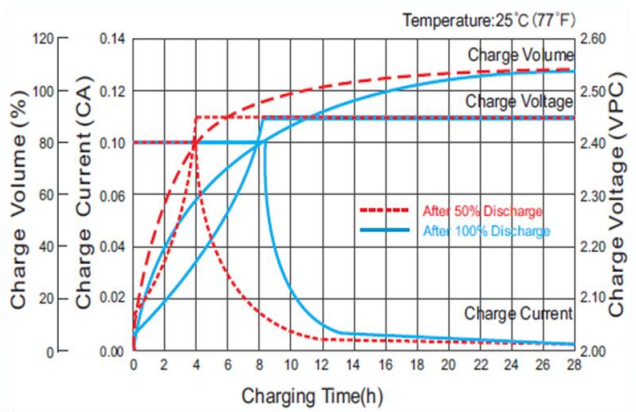

Cycle Life vs. Depth of Discharge (25°C)

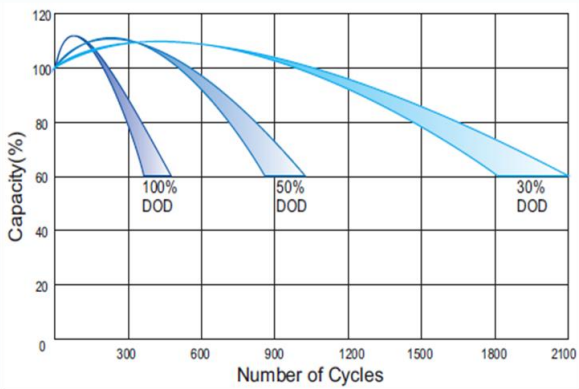

Temperature Effects on Capacity

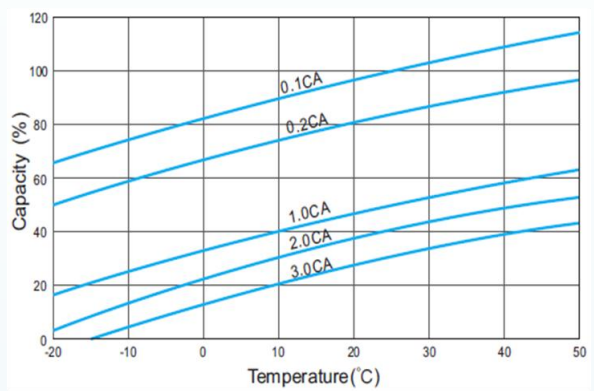

Effect of Temperature on Long Term Life

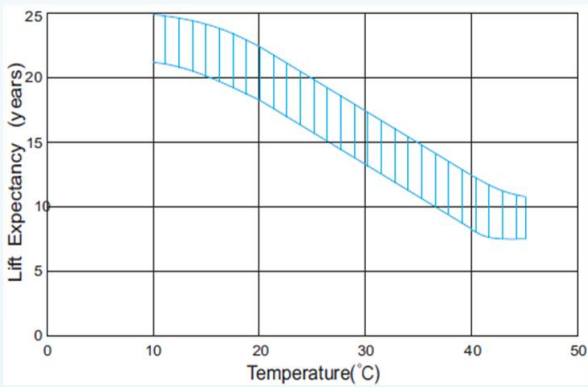

Storage Characteristics

